

Section 2.00 – Construction of Language

For the purpose of this Ordinance certain terms or words used herein shall be interpreted as follows:

- A. The word "person" includes a firm, association, organization, partnership, trust, company, or corporation, as well as an individual.
- B. The phrase "single ownership" shall include ownership by a person, firm, association, organization, partnership, trust, company, corporation or other individual legal entity.
- C. The present tense includes the future tense. The singular number includes the plural, and the plural number includes the singular.
- D. The word "shall" is always mandatory. The word "may" is permissive.
- E. The phrases "used for" and "occupied for" shall include the phrases "intended for", "designed for", "maintained for", or "arranged for".
- F. Words and terms not herein defined shall have the meaning customarily assigned to them.

Section 2.01 – Definitions

Accessory Building: A detached or attached building or structure, the use of which is clearly incidental to that of the main building(s) or to the use of the land. Children's play equipment shall not be considered an accessory building, nor a habitable second floor bedroom or office. *(amended 02.17.04)*

- A. Detached Accessory Building: A building or structure that is incidental to, does not share a common wall with, or is not connected to the main building(s) by an enclosed breezeway. Such buildings include, but are not limited to, pole barns, garages, in-ground swimming pools and above-ground pools with a surrounding deck structure.
- B. Attached Accessory Building: A non-habitable building or structure that is incidental to, shares a common wall with, or is connected to the main building(s) by an enclosed breezeway. Such buildings include, but are not limited to, garages, storage rooms and workshops.

Accessory Use: An accessory use is a use which is clearly incidental to, customarily found in connection with, and is located on the same zoning lot as the principal use to which it is related.

Access Road, Marginal: See Marginal Access Road.

Adult Day-Care Facility: *(added 08.06.07)*

- A. Adult Family Day-Care Home. A private home in which six (6) or less adults eighteen (18) years of age or older, receive care for periods of less than twenty-four (24) hours a day. It includes facilities for adults who are aged, mentally ill, developmentally disabled, or physically handicapped that require supervision on an ongoing basis. An adult day care home does not include alcohol or substance abuse rehabilitation centers, residential centers for persons released from or assigned to a correctional facility, or any other facilities which do not meet the definition of adult day care center.
- B. Adult Group Day-Care Home. A private home in which more than six (6) but not more than twelve (12) adults eighteen (18) years of age or older, receive care for periods of less than twenty-four (24) hours a day. It includes facilities for adults who are aged, mentally ill, developmentally disabled, or physically handicapped that require supervision on an ongoing basis. An adult day care home does not include alcohol or substance abuse rehabilitation centers, residential centers for persons released from or assigned to a correctional facility, or any other facilities which do not meet the definition of adult day care center.

- C. Adult Day-Care Center. A facility, other than a private residence, receiving one or more persons, eighteen (18) years of age or older, for care for periods of less than twenty-four (24) hours a day. It includes facilities for adults who are aged, mentally ill, developmentally disabled or physically handicapped that require supervision on an ongoing basis. An adult day-care center does not include alcohol or substance abuse rehabilitation centers, residential centers for persons released from or assigned to a correctional facility, or any other facilities which do not meet the definition of adult day-care center.

Adult Foster Care Facility: A state-licensed establishment that provides foster care to adults. It includes facilities and foster care homes for adults who are aged, mentally ill, developmentally disabled, or physically handicapped who require supervision on an ongoing basis but who do not require continuous nursing care. An adult foster care facility does not include convalescent or nursing homes, homes for the aged, hospitals, alcohol or substance abuse rehabilitation center, residential centers for persons released from or assigned to a correctional facility, or any other facilities which have been exempted from the definition of adult foster care facility by the Adult Foster Care Facility Licensing Act, MCL 400.701, et. seq.; MSA 16.610 (61), et. seq., as amended. The following additional definitions shall apply in the application of this Ordinance: *(amended 08.06.07)*

- A. Adult Foster Care Family Home. A private residence with the approved capacity to receive six (6) or fewer adults to be provided supervision, personal care, and protection in addition to room and board, twenty-four (24) hours a day, five (5) or more days a week and for two (2) or more consecutive weeks. The adult foster care family home licensee must be a member of the household and an occupant of the residence. *(amended 08.06.07)*
- B. Adult Foster Care Small Group Home. An owner-occupied facility with the approved capacity to receive twelve (12) or fewer adults who are provided supervision, personal care, and protection in addition to room and board, for twenty-four (24) hours a day, five (5) or more days a week, and for two (2) or more consecutive weeks. *(amended 08.06.07)*
- C. Adult Foster Care Large Group Home. A facility with approved capacity to receive at least thirteen (13) but not more than twenty (20) adults to be provided supervision, personal care, and protection in addition to room and board, twenty-four (24) hours a day, five (5) or more days a week, and for two (2) or more consecutive weeks. *(amended 08.06.07)*
- D. Adult Foster Care Congregate Facility. An adult foster care facility with the approved capacity to receive more than twenty (20) adults to be provided with foster care. *(amended 08.06.07)*

Agricultural: See Farm.

Airport: A tract of land that is maintained for the take-off and landing of aircraft and that has facilities for the shelter, supply, and repair of such aircraft.

Alley: A public or private right-of-way which provides secondary access to a lot, block or parcel of land. *(amended 04.21.03)*

Alterations: Any change, addition or modification to a structure or type of occupancy, any change in the structural members of a building such as wall or partitions, columns, beams or girders, or any change which may be referred to herein as "altered" or "reconstructed".

Apartment: The dwelling unit in a multiple dwelling as defined herein:

- A. Efficiency Apartment. A dwelling unit consisting of not more than one (1) room in addition to kitchen and necessary sanitary facilities.
- B. One Bedroom Unit. A dwelling unit consisting of not more than two (2) rooms in addition to kitchen and necessary sanitary facilities, and for the purposes of computing density shall be considered a two (2) room unit.

- C. **Two Bedroom Unit.** A dwelling unit consisting of not more than three (3) rooms in addition to kitchen and necessary sanitary facilities, and for the purposes of computing density, shall be considered as a three (3) room unit.
- D. **Three or More Bedroom Unit.** A dwelling unit consisting of four (4) or more rooms in addition to kitchen and necessary sanitary facilities, and for the purposes of computing density shall be considered a four (4) room unit.

Apartment House: See Dwelling, Multiple Family.

Assisted Living Facility: A multiple-family housing form which offers as needed assistance with such daily activities as eating, bathing, dressing, laundry, housekeeping and medications, and sometimes includes centers for medical care. Each dwelling unit may or may not contain cooking and laundry facilities. *(amended 08.06.07)*

Automobile: For the purposes of this Ordinance, "automobile" shall include automobiles, pickup trucks, vans, campers, motorcycles, and similar motor-driven wheeled vehicles. This definition shall not include tractor trailers, semi-trucks, construction equipment, and similar types of heavy commercial vehicles.

Automobile Dealership: A building or premises used primarily for the sale of new and used automobiles and which may include related repair and service activities.

Automobile Repair Garage: An enclosed building where the following services may be carried out: general repairs, engine rebuilding, rebuilding or reconditioning of motor vehicles; collision services such as frame or fender straightening and repair; painting and undercoating of automobiles; and automobile glass work.

Automobile Service Center: An enclosed building used primarily for the sale and installation of major automobile accessories such as tires, batteries, radios, air conditioners, and mufflers; and such services as brake adjustment, and wheel alignment and balancing, electric vehicle recharge stations or battery exchanges; but excluding any major mechanical repairs, collision work, undercoating or painting, or glass work. The sale of gasoline (stored in underground tanks) shall be incidental to the above enumerated activities. *(amended 09.21.09)*

Automobile Wash Establishment: A building or portion thereof where automobiles are washed as a commercial enterprise.

Bank: An establishment that exists primarily for the custody, loan, exchange, or issue of money, for the extension of credit, and for facilitating the transmission of funds by drafts or bills of exchange. It shall include a credit union and a savings and loan establishment, but shall not include retail businesses that contain an automatic teller machine.

Basement: That portion of a building which is partially or wholly below grade but so located that the vertical distance from the average grade to the floor is greater than the vertical distance from the average grade to the ceiling. A basement

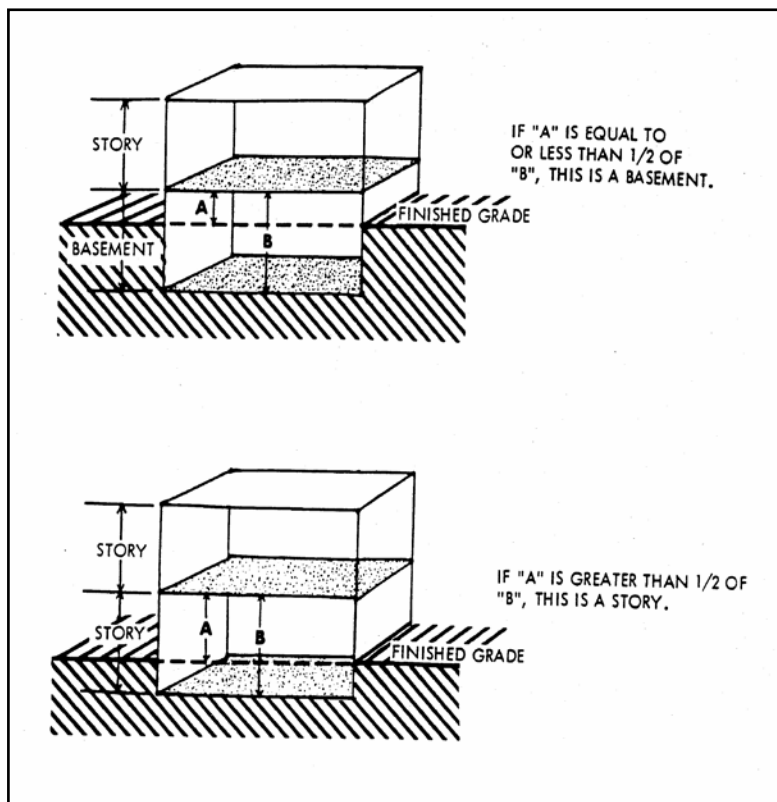

Illustration 2.1

shall not be counted as a story. This definition shall not include an earth-bermed or earth-sheltered house. (See Illustration 2.1)

Bed and Breakfast: A house, or portion thereof, where short-term lodging rooms and meals are provided. The operator of the bed and breakfast shall live on the premises. (amended 10.01.01)

Berm: A continuous, raised earthen mound with a flat top and sloped sides and planted with shrubs, grass, and trees or suitable ground cover in accordance with the Greenbelt Section of this Zoning Ordinance, constructed to sufficient height, length and width to act as a screening barrier where required by this Ordinance.

Block: A parcel of land bounded by streets or by a combination of streets and public parks, cemeteries, railroad rights-of-way, shorelines, or the corporate boundary lines of any village, city or township.

Board: The Zoning Board of Appeals of the Charter Township of Orion.

Boarding House: A dwelling where meals, or lodging and meals are provided for compensation and where one or more rooms are occupied by persons by pre-arrangement for definite periods of not less than one week. A boarding house is to be distinguished from a hotel, motel, or a convalescent or nursing home. A rooming house or a furnished room shall be deemed a boarding house for the purposes of this Ordinance.

Boat Livery: Any premises on which boats or floats of any kind are kept for the purpose of renting, leasing, or providing use thereof to persons other than the owners for a charge or a fee.

Buildable Area: The area remaining on a lot or parcel after yard, parking, or any other requirements of this Ordinance have been met.

Buildable Land: That land which because of its topography and soil and subsoil characteristics is capable of supporting the construction of a structure.

Building: Any structure, temporary or permanent, having one or more floors and a roof, and intended for the shelter or enclosure of persons, animals, or property, and including gazebos, and covered and screened porches. (amended 02.17.04)

Building Height: On a rectangular building, the vertical distance measured from the established grade to the highest point of the roof. On a building with a ridged roof, the vertical distance between the established grade to a point halfway up the triangular wall area enclosed by the sloping ends of the ridged roof. Where a building is located on a terrace or slope, the height shall be measured from the average ground level of the building wall. (See Illustration 2.2).

Building, Main or Principal: A building or, where the context so indicates, a group of buildings which are permanently affixed to the land and which are built, used, designed, or intended for the shelter or enclosure of the main or principal use of the lot.

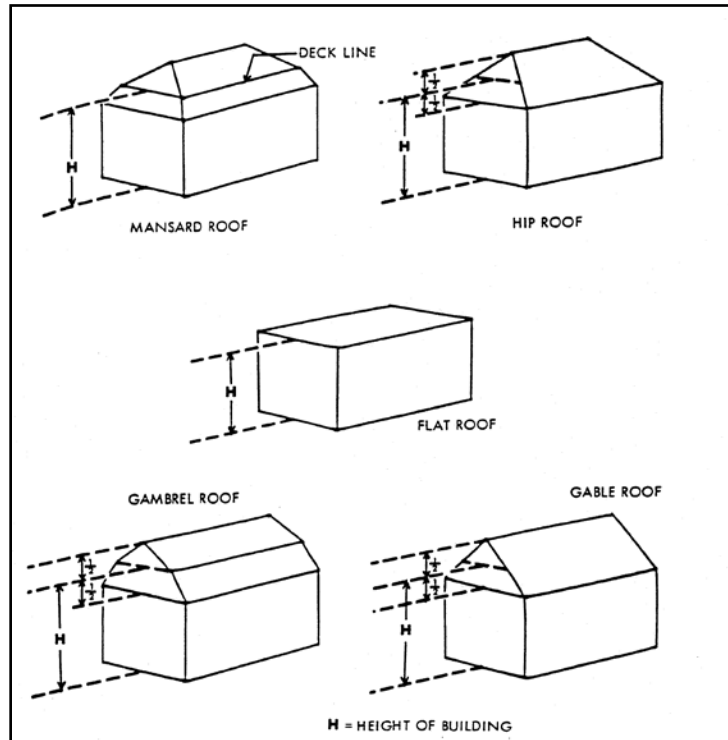

Illustration 2.2

Building Official: The Building Inspector or Official designated by the Orion Township Board, or his authorized representative, charged with the responsibility of enforcing this Ordinance.

Building Permit: The written authority issued by the Building Official of Orion Township or his authorized agent permitting the construction, removal, moving, alteration, or use of a building in conformity with the provisions of this Ordinance.

Bulk: Bulk is the term used to indicate the size and setbacks of buildings or structures and the location of same with respect to one another, and includes:

- A. Height and area of buildings.
- B. Location of exterior walls in relation to lot lines, streets, and other buildings.
- C. Gross floor area of buildings in relation to lot area.
- D. All open spaces allocated to buildings.
- E. Amount of lot area required for each dwelling unit.

Business Establishment: A business establishment is a place of business carrying on operations, the ownership and management of which are separate and distinct from those of any other place of business located on the same lot.

Carport: A partially open shelter or structure for housing automobiles. Such structures shall comply with all yard requirements applicable to garages.

Cemetery: Any land used or intended to be used for the burial of the human dead or animal dead, and dedicated for such purposes.

Center: A child care center or day care center which is a facility other than a private residence, which receives one (1) or more preschool or school age children for care for periods of less than 24 hours a day, and at which the parents or guardians are not immediately available to the children. It includes a facility that provides care for not less than two (2) consecutive weeks, regardless of the number of hours of care per day. The facility is generally described as a child care center, day care center, day nursery, nursery school, parent cooperative preschool, child kindergarten, play group, or drop-in center. *(amended 10.26.00)*

Child Day-Care Facilities: *(amended 08.06.07)*

- A. Child Family Day-Care Home. A private home in which one (1) to six (6) minor children are received for care and supervision for periods of less than twenty-four (24) hours a day, unattended by a parent or legal guardian, except children related to an adult member of the family by blood, marriage or adoption. Family day care home includes a home that gives care to an unrelated minor child for more than four (4) weeks during a calendar year.
- B. Child Group Day-Care Home. A private residence in which between seven (7) but not more than twelve (12) minor children are received for care and supervision for periods less than twenty-four (24) hours a day unattended by a parent or legal guardian, excepting children related to an adult member of the family by blood, marriage or adoption. It includes a home that gives care to an unrelated child for more than four (4) weeks in a calendar year.
- C. Child Day-Care Center. A facility, other than a private residence, receiving more than one (1) or more children for care and supervision for periods less than twenty-four (24) hours, and where the parents or guardians are not immediately available to the child. It includes a facility that provides care for not less than two (2) consecutive weeks, regardless of the number of hours of care per day. The facility is generally described as a child care center, day care center, day nursery, nursery school, parent cooperative preschool, child kindergarten, play group, or drop-in center.

Child Foster Family Facilities: *(amended 08.06.07)*

- A. Child Foster Family Home. A private home in which one (1) but not more than four (4) minor children, who are not related to an adult member of the household by blood, marriage, or who are not placed in the household pursuant to the adoption code, Chapter X of Act No. 288 of the Public Acts of 1939, being sections 710.21 to 710.70 of the Michigan Compiled Laws, are given care and supervision for twenty-four (24) hours

a day, for four (4) or more days a week, for two (2) or more consecutive weeks, unattended by a parent or legal guardian.

- B. **Child Foster Family Group Home.** A private home in which more than four (4) but fewer than seven (7) minor children, who are not related to an adult member of the household by blood, marriage, or who are not placed in the household pursuant to Chapter X of Act No. 288 of Public Acts of 1939, are provided care for twenty-four (24) hours a day, for four (4) or more days a week, for two (2) or more consecutive weeks, unattended by a parent or legal guardian.

Clinic: A place for the care, diagnosis, and treatment of sick or injured persons, and those in need of medical or minor surgical attention. A clinic may incorporate customary laboratories and pharmacies incidental or necessary to its operation or to the service of its patients, but may not include facilities for in-patient care or major surgery.

Club: An organization of persons for special purposes or for the promulgation of sports, arts, science, agriculture, literature, politics, or similar activities, but in no way operated for profit.

Cluster Lots or Cluster Lotting: Those lot arrangements within recorded plats as permitted under the terms of this Ordinance wherein the lot sizes are smaller than the principal permitted size in the district, said smaller size resulting from the permitted lot clustering provisions of this Ordinance.

Commercial Equipment: Any machinery, parts, accessories, construction equipment or other equipment used primarily in the course of conducting a trade or business. *(amended 11.19.01)*

Commercial Use: The use of property in connection with or for the purchase, sale, barter, display, or exchange of goods, wares, merchandise, or personal services, and the maintenance or operation thereof of offices, or recreational or amusement enterprises.

Commercial Vehicle: A vehicle of the bus, truck, van or trailer-type, which is designed, constructed or used for the transportation of passengers for compensation, the delivery of goods, wares or merchandise, the drawing or towing of other vehicles or construction equipment, or for other commercial purposes. The term includes, but not to the exclusion of any other types not specifically mentioned herein, truck-trailers, step-vans, dump trucks, tow-trucks, pickup trucks and sedan or panel trucks in excess of three (3) ton pay load capacity primarily for commercial purposes, and pole trailers. *(amended 11.19.01)*

Commission: The Planning Commission of the Charter Township of Orion.

Community Impact Statement: An assessment of the developmental, ecological, social, economic, and physical impacts of a Planned Unit Development on and surrounding the development site.

Condominium: A building or lot governed under Act 59, Public Acts of 1978, as amended. The following condominium terms shall apply in the application of this Chapter: *(amended 11/07/11)*

1. **Condominium Documents:** The master deed, recorded pursuant to the Condominium Act, and any other instrument referred to in the master deed or bylaws that affects the rights and obligations of a co-owner in the condominium.
2. **Condominium Lot:** The condominium unit and the contiguous limited common element surrounding the condominium unit, which shall be the counterpart of the "lot" as used in connection with a project developed under the Land Division Act, Act 288 of the Public Acts of 1967, as amended.
3. **Condominium Unit:** The portion of a condominium project designed and intended for separate ownership and use, as described in the master deed.
4. **General Common Elements:** A portion of the common elements reserved in the master deed for the use of all of the co-owners.

5. **Limited Common Elements:** A portion of the common elements reserved in the master deed for the exclusive use of less than all of the co-owners.
6. **Master Deed:** The condominium document recording the condominium project to which are attached as exhibits and incorporated by reference, the bylaws for the project and the condominium subdivision plan for the project, and all other information required by Section 8 of the Condominium Act.
7. **Site Condominium:** A condominium development containing residential, commercial, office, industrial, or other structures or improvements for uses permitted in the zoning district in which the condominium development is located, in which each co-owner owns the exclusive right to a volume of space within which each co-owner may construct a structure or structures.

Construction Equipment: A bulldozer, front-end loader, backhoe, power shovel, cement mixer, trenchers, and any other equipment designed or used for commercial construction purposes, including parts and accessories thereto, or trailers designed for the transportation of such equipment. *(amended 11.19.01)*

Convalescent or Nursing Home: A state licensed facility for the care of children, of the aged or infirm, or a place of rest for those suffering bodily disorders. Said home shall conform and qualify for license under State law even though State law has different size regulations. *(amended 08.06.07)*

Co-op (Cooperative): A residential or commercial building or group of buildings owned jointly in which the benefits or profits are shared by the common owners.

Court: An open unoccupied space other than a yard, and bounded on at least two sides by a building. A court extending to the front lot line or front yard, or to the rear lot line or the rear yard is an "Outer Court". Any other court is an "Inner Court".

Day Care Home, Family: A private home in which one (1) to six (6) minor children are received for care and supervision for periods of less than twenty-four (24) hours a day, unattended by a parent or legal guardian, except children related to an adult member of the family by blood, marriage or adoption. Family day care home includes a home that gives care to an unrelated minor child for more than four (4) weeks during a calendar year. *(amended 02.17.94)*

Day Care Home, Group: A private home in which more than six (6) but not more than twelve (12) minor children are given care and supervision for periods of less than twenty-four (24) hours a day unattended by a parent or legal guardian, except children related to an adult member of the family by blood, marriage or adoption. Group day care home includes a home that gives care to an unrelated minor child for more than four (4) weeks during a calendar year. *(amended 02.17.94)*

Deck: A structure for outdoor residential activities greater than twelve (12) inches above the average grade, and constructed on an elevated foundation that may include joists, beams or posts. Decks are not considered accessory buildings, but are subject to setback and total lot coverage provisions. *(added 02.17.04)*

Density: The number of dwelling units developed on an acre of land. As used in this Ordinance, all densities are stated in dwelling units per acre.

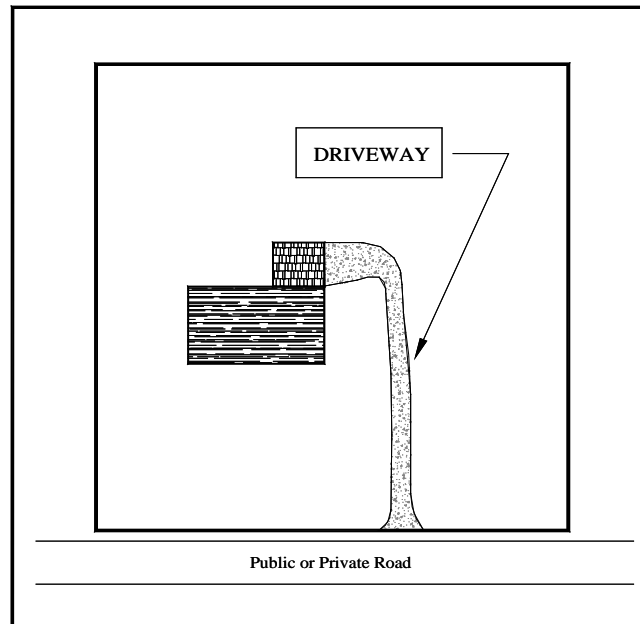

Illustration 2.9

District: A portion of the unincorporated area of the Township of Orion within which, on a uniform basis, certain uses of land and buildings are permitted, and within which certain regulations and requirements apply under the provisions of this Ordinance.

Drive-in: See Restaurant, Drive-In.

Driveway: A strip of land, that is not dedicated to the public, used to provide vehicular access to a single zoning lot. (See Illustration 2.9) *(added 04.21.03)*

Dwelling, Single-Family: A detached or attached residential dwelling unit other than a mobile home, designed for and occupied by one (1) family only, and having individual entranceways and garage facilities. Attached residential dwelling units, also known as cluster housing units, share a common wall.

Dwelling, Two-Family or Duplex: A detached building or structure designed for and occupied by two (2) families only, with separate housekeeping, cooking and bathroom facilities for each.

Dwellings, Multiple-Family: A building or structure designed for and occupied by three (3) or more families with separate housekeeping, cooking and bathroom facilities for each. Multiple family dwellings are commonly served by a common entranceway or foyer and generally do not have individual garage facilities. (Refer to "Apartments" definition for dwelling unit types.)

Dwelling Unit: A single unit providing complete, independent living facilities for one or more persons, including permanent provisions for living, sleeping, eating, cooking, and sanitation. *(amended 08.05.99)*

Earth-Sheltered Home: A complete building partially below grade that is intended to be used as a single-family dwelling as indicated by the building's design blueprints.

Easement: A specific area of land over which a liberty, privilege, or advantage is granted by the owner to the public, a corporation, or some particular person or part of the public for specific uses and purposes, and which shall be designated a 'public' or 'private' easement, depending on the nature of the use. *(amended 04.21.03)*

Efficiency Unit: See Apartment, Efficiency.

Electric Vehicle: Any vehicle that is licensed and registered for operation on public and private highways, roads, and streets either partially or exclusively, on electrical energy from the grid, or an off-board source, that is stored on-board via a battery for motive purpose. Electric vehicle includes: (1) a battery electric vehicle; and (2) a plug-in hybrid electric vehicle. *(added 01.03.17)*

Electric Vehicle Charging Station: A public or private parking space that is served by battery charging station equipment that has as its primary purpose the transfer of electric energy (by conductive or inductive means) to a battery or other energy storage device in an electric vehicle. *(added 01.03.17)*

Enclosed Breezeway: A structure with a roof connecting a detached accessory building and the principal structure on the lot. *(added 02.17.04)*

Enclosed Mall: A shopping center wherein all stores, offices, shops, walkways, and corridors are enclosed under a common roof, and all serviced by common means of access for retail purposes.

Enforcement Officer: The enforcement officer is the person and assistants designated by the Supervisor as being responsible for enforcing and administering all requirements of this Zoning Ordinance and the Township Building Code.

Entrance Ramp: A roadway used for access from a feeder road to a limited access highway.

Erected: Includes built, constructed, altered, reconstructed, moved upon, or any physical operations on the premises required for construction. Excavation, fill, drainage, and the like shall be considered part of erection.

Essential Services: Shall mean the erection, construction, alteration, or maintenance by Public Utilities or Municipal Governments, Departments, Commissions, or Boards, or by other governmental agencies of underground, surface or overhead gas, electric, steam, or water transmission or distribution systems, collection, communications, supply, or disposal systems, including public safety communication towers, structures and facilities, dams, weirs, culverts, bridges, canals, locks, including poles, wires, mains, drains, sewers, towers, pipes, conduits, cables, fire alarm boxes, police call boxes, traffic signals, or signs and fire hydrants, and other similar equipment and accessories in connection therewith, reasonably necessary for the furnishing of adequate service by such Public Utilities or Municipal Departments, Commissions, or Boards, or other governmental agencies, or for the public health, safety, or general welfare, and buildings which are primarily enclosures or shelters of such essential services equipment. An essential service shall not include other buildings associated with an essential service, or cellular telephone facilities, including cellular telephone transmitting towers, the use of essential service public safety communication towers, structures and facilities for cellular telephone or other wireless communication facilities, or commercial broadcast television and radio facilities. *(amended 09.02.14)*

Excavation: The removal or movement of soil, sand, stone, gravel, or fill dirt except for common household gardening, farming, and general ground care.

Exception: Certain uses, such as electrical substations or water pumping stations, considered by the Township Board to be essential or desirable for the welfare of the community, and which are entirely appropriate and not essentially incompatible with the basic uses in any zone. However, such exceptions may not be placed at every or any location or without conditions being imposed by reason of special problems the use presents from a zoning standpoint.

Exit Ramp: A roadway used for access from a limited access highway to a feeder road.

Extended Hour Uses: An office, retail, restaurant, or service establishment operating regularly scheduled business hours eighteen (18) or more hours per day. *(added 02.21.06)*

Family: *(amended 01.17.85)*

- A. One or more persons related by blood or marriage occupying a dwelling unit and living as a single, nonprofit housekeeping unit.
- B. A collective number of individuals living together in one house under one head, whose relationship is of a permanent order, nor include a group of individuals whose association is temporary and resort-seasonal in character or nature.
- C. A family is distinguished from a group occupying a rooming house, boarding house, lodging house, club, fraternity house, hotel, motel, tourist home or foster care group home.

Farm: All of the contiguous neighboring or associated land operated as a single unit on which bona fide farming is carried on directly by the owner-operator, manager or tenant farmer, by his own labor or with the assistance of members of his household or hired employees; provided, however, that land to be considered a farm hereunder shall include a contiguous parcel of forty (40) acres or more in area; provided further, farms may be considered as including accessory farm buildings, the principal residence, and establishments operated as bona fide greenhouses, nurseries, orchards, chicken hatcheries, poultry or livestock farms, and apiaries.

It excludes the raising of fur bearing animals, riding stables, animal kennels and establishments for the disposal or feeding of public garbage, rubbish or offal to animals.

Farm Buildings: Any building or structure other than a dwelling, moved upon, maintained, used or built on a farm which is essential and customarily used on farms of that type for the pursuit of their agricultural activities.

Fast Food Restaurant: See Restaurant, Fast-Food.

Fence: Any permanent partition, structure or gate of definite height and location erected as a dividing marker, barrier or enclosure.

Fence, Obscuring (Walls): A structure constructed of a permanent, durable material and of definite height and location to serve as an obscuring screen in carrying out the requirements of this Ordinance.

Filling: The depositing or dumping of any matter onto, or into the ground, except common household gardening and general farm care.

Flood Plain: The area adjoining a river stream, water course or lake subject to a one hundred (100) year recurrence-interval flood, as delineated by the Federal Insurance Administration of the Department of Housing and Urban Development "Flood Hazard Boundary" maps. The flood plain shall include the stream channel and the overbank area (the floodway) and the fringe areas of the floodway. No building shall be constructed in a flood plain.

Floor Area: See Structure Area.

Floor Area, Residential: For the purpose of computing the minimum allowable floor area in a residential, one-family dwelling unit, the sum of the horizontal areas of each story of a building shall be measured from the exterior faces of the exterior walls. The floor area measurement is exclusive of areas of basements, unfinished attics, attached garages, or space used for off-street parking, breezeways, enclosed and unenclosed porches, and accessory structures.

In the case of two-family or multi-family dwellings, the minimum allowable floor area of a dwelling unit is the horizontal floor area of the dwelling unit measured to the interior face of the dwelling unit's perimeter walls, excluding hallways and common areas.

Foster Child: A child unrelated to a family by blood or adoption with whom he or she lives for the purposes of care and/or education.

Front Setback for a Structure: In determining the placement of a structure on a lot, the front building setback line shall be measured from the future right-of-way line as provided in the map of Road Right-of-Way Widths within the Charter Township of Orion Master Plan or from the acquired highway easement whichever is greater. This provision relates solely to the measurement made for locating a structure on a lot, and is not intended to limit use of the property in other respects. Unless and until the area between the existing and future right-of-way lines is acquired or dedicated for public use, such area shall in all respects, be considered to be private property for private use. Thus, for determining density of use and other calculations relating to the layout and substantive use rights of the property, the existing right-of-way line shall be applicable (or highway easement, whichever is greater). *(added 07.16.18)*

Garage, Private: An accessory building designed or used for the storage of not more than three (3) motor vehicles owned and used by the occupants of the building to which it is accessory. A garage may be either attached to or detached from the principal structure.

Garage, Storage: Any premises except those herein defined as private garage, used exclusively for the storage of self-propelled vehicles, and where such vehicles are not repaired.

Garbage: All wastes, animal, fish, fowl or vegetable matter incidental to the preparation, use and storage of food for human consumption, spoiled food, dead animals, animal manure and fowl manures.

Gasoline Service Station: A place for the dispensing, sale, or offering for sale of motor fuels directly to users of motor vehicles, together with the sale of motor fuels directly to users of motor vehicles, together with the sale of minor accessories and services for motor vehicles, but not including major automobile repair. (Also see Automobile Repair Garage & Service Center.)

Golf Driving Range: The premises on which golf balls are hit for practice purposes including any related sales/office structure.

Golf Course (Country Club): The premises upon which the game of golf is played, including club houses, parking lots, swimming pools, tennis courts or other structures or uses customarily incidental to a golf course or a country club; provided, however, that a golf course shall include a minimum of nine holes.

Grade: The elevation of the curb at the mid-point of the front of the lot. Where no curb exists, the grade shall be the average elevation of the street adjacent to the property line. When the word "grade" is used herein in relation to a building, it shall mean the line on the foundation wall where the ground meets or is intended to meet the wall, unless such has been officially established.

Greenbelt: A strip of land of definite width and location reserved for the planting of shrubs and/or trees to serve as an obscuring screen or buffer for noise and/or sight relief in carrying out the requirements of this Ordinance.

Habitable Space: Space in a structure for living, sleeping, eating or cooking. Bathrooms, toilet rooms, closets, halls, storage or utility spaces and similar areas are not considered habitable spaces. *(added 02.17.04)*

Home Occupation: Any use customarily conducted entirely within the dwelling and carried on by the occupants thereof, which use is clearly incidental and secondary to the use of the dwelling for dwelling purposes and does not change the character thereof. *(amended 08.01.11)*

Hospital: A building, structure or institution in which sick or injured persons are given medical or surgical treatment and operating under license by the Health Department and the State of Michigan, and is used for primarily in-patient services, and including such related facilities as laboratories, out-patient departments, central service facilities, and staff offices.

Hotel and Motel: A series of dwelling units designed primarily for occupancy by transients located in one or more buildings wherein each unit has a separate entrance. No kitchen or cooking facilities are permitted with the exception of units for occupancy by the manager and/or caretaker. Units shall contain not less than two hundred fifty (250) square feet of floor space.

Housing for the Elderly: A building or group of buildings containing dwellings intended for, and solely occupied by, elderly persons as defined by the Federal Fair Housing Amendments Act of 1988. Housing for the elderly may include independent and/or assisted living arrangements but shall not include convalescent or nursing facilities regulated by the State of Michigan. *(added 08.06.07)*

Independent Living Facility: A multiple-family housing form which provides housing for those people who are able to live independently but do not wish to maintain a home. These facilities also cater to those of the same age and offer prepared meals and social activities/amenities. Assistance with activities of daily living is not provided by the facility. *(added 08.06.07)*

Industrial Park: An industrial park is a special type of planned industrial subdivision or building designed and equipped to accommodate a variety of industrial uses, providing them with all necessary facilities, services, and utilities in attractive surroundings among compatible neighbors. Industrial parks may be promoted or developed by private developers, community organizations, or government organizations.

Junk: Any motor vehicles, machinery, appliances, product or merchandise with parts missing or scrap metals or other scrap materials that are damaged, deteriorated, or are in a condition which prevents their use for the purpose for which the product was manufactured. This definition specifically includes motor vehicles not movable under their own power.

Junk Yard: An open area where waste, used, or secondhand materials are bought and sold, exchanged, stored, baled, packed, disassembled, or handled including, but not limited to: junk, scrap iron, and other metals, paper, rags, rubber tires, and bottles.

A "junk yard" includes automobile wrecking yards and includes any area used for storage, keeping or abandonment of junk but does not include uses established entirely within enclosed buildings.

Kennel: Any lot or premises on which three (3) or more dogs, cats, or other domestic animals, four (4) months or more old, are kept, either permanently or temporarily, either for sale, breeding, boarding, training, hobby, protection, or pets.

Laboratory: A place devoted to experimental study, such as testing and analyzing. Manufacturing of product or products is not to be permitted within this definition.

Landfill: Any disposal area or tract of land, building, unit or appurtenance or combination thereof that is used to collect, store, handle, dispose of, bury, cover over, or otherwise accept or retain refuse as herein defined.

Land Use Plan: See Master Plan.

Landing Area: A parcel of land or an excepted parcel of land or an outlot of a subdivision having hard-surfaced runways and taxiways but not having areas used for the storage or maintenance of aircraft. Such landing area shall be used exclusively for the landing and taking off of fixed-wing, propeller-driven aircraft.

Large Scale Retail Establishment: A retail establishment commonly referred to as a "big box" store, which exceeds fifty-five thousand (55,000) square feet in gross floor area for a single tenant. *(added 07.07.03)*

Light Assembly: Manufacture of light products, predominantly from previously prepared materials, of finished products or parts, such as industrial controls; electronic components and accessories; measuring, analyzing, and controlling instruments; photographic (except chemicals and sensitized materials); medical, optical goods; and other similar forms of light products assembly, as determined by the Planning Commission. Light assembly shall not include the fabrication, machining, stamping or forming of metal, plastic, or other materials, unless such fabrication, machining, stamping or forming is for incidental repair or as part of product development or research, experimentation, demonstration and/or training. *(added 08.15.05)*

Livestock: Horses, cattle, sheep, goats, and other useful animals normally kept or raised on a farm.

Loading Space, Off-Street: An area that is safely and conveniently located for pickups and deliveries, scaled to delivery vehicles expected to be used, and accessible to such delivery vehicles when required off-street parking spaces are filled. Required off-street loading space is not to be included in the computation of required off-street parking space.

Lot: Part of a subdivision, the plat of which has been recorded in the office of the Oakland County Register of Deeds; or a plot of land, the deed of which has been recorded in the office of the Oakland County Register of Deeds.

Lot Area: The total horizontal area within the lot lines of the lot. For lots adjacent to private or public roads, the lot area shall not include any portion of the private or public road or road right-of-way. *(amended 04.21.03)*

Lot, Contiguous: Lots or parcels of land adjoining each other and under the same ownership.

Lot, Corner: A lot of which at least two (2) adjacent sides abut their full length upon a street, provided that such two sides intersect at an angle of not more than one hundred thirty-five (135°) degrees. Where a lot is on a curve, if tangents through the extreme point of the street line of such lot make an interior angle of not more than one hundred thirty-five (135°) degrees, it is a corner lot. In the case of a corner lot with curved street line, the corner is that point on the street lot line nearest to the point of intersection of the tangents described above. (A tangent is a straight line extended from the outer edges of a curve which intersect to form a corner.) (See Illustration 2.5)

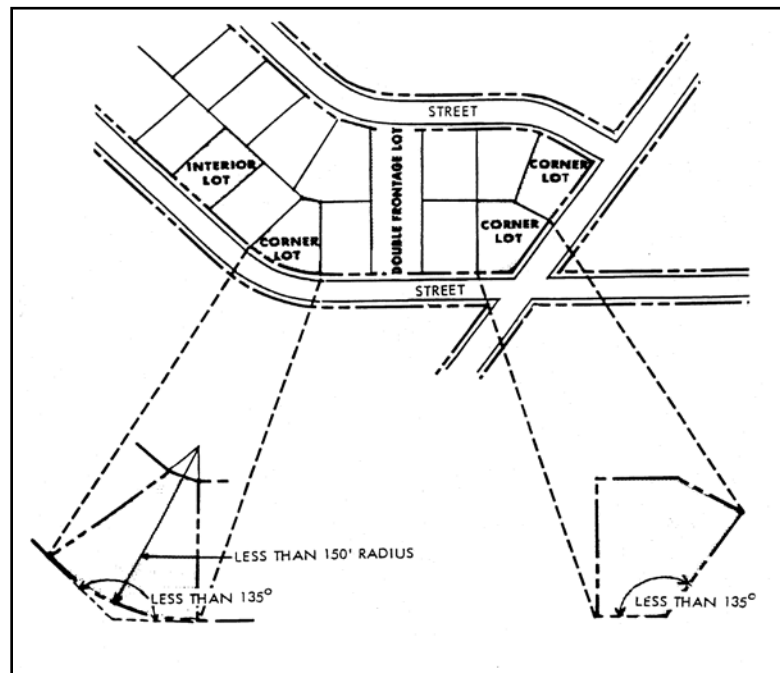

Illustration 2.5

Lot Coverage: The part or percent of the lot occupied by buildings or structures, including accessory buildings or structures.

Lot Depth: The horizontal distance between the front and rear lot lines, measured along the median between side lot lines.

Lot, Double Frontage: An interior lot having frontages on two (2) more or less parallel streets or having frontage on a street and on a lake or canal as distinguished from a corner lot. In the case of a row of double frontage lots, one side shall be designated as a front on the plat and on the request for a building permit.

Lot, Interior: Any lot other than a corner lot.

Lot, Lakefront: A lot adjoining or abutting a lake or a canal. Either the street-side or the lake-side shall be designated as the front on the plat and on the request for a building permit.

Lot Lines: The lines bounding a lot as defined herein:

- A. **Front Lot Line.** In the case of a lot not located on a corner, the line separating said lot from the public or private road right-of-way. In the case of a corner lot, or double frontage lot, that line separating said lot from the road which is designated as the front road in the plat and on the request for a building permit. For the purpose of determining setbacks, front yard setbacks shall be required for each lot line that abuts a public or private road right-of-way. A front yard setback for the frontage along a private road shall not however be required for existing or proposed structure(s) on neighboring parcels adjoining a private road right-of-way and which are not subject to land division permits under Ordinance No. 27 or Ordinance No. 60. *(amended 04.21.03)*
- B. **Rear Lot Line.** Ordinarily, that lot line which is opposite and most distant from the front lot line of the lot. In the case of an irregular or triangular lot, a line ten (10) feet in length entirely within the lot parallel to and at the maximum distance from the front lot line of the lot shall be considered to be the rear lot line for the purpose of determining depth of rear yard. In cases where none of these definitions are applicable, the Building Inspector shall designate the rear lot line.
- C. **Side Lot Line.** Any lot lines other than the front lot line or rear lot line. A side lot line separating a lot from a street is a side street lot line. A side lot line separating a lot from another lot or lots is an interior side lot line.

Lot of Record: A lot which is part of a subdivision recorded in the Office of the County Register of Deeds, or a lot or parcel described by metes and bounds, the description of which has been so recorded and is considered as such for tax purposes.

Lot Width: The horizontal, straight line distance between the side lot lines measured at the two points where the minimum building line or setback intersects the side lot lines. The width of a private road right-of-way shall not be included in the calculation of frontage necessary to achieve the minimum lot width requirements. *(amended 04.21.03)*

Lot, Zoning: A single tract of land, located within a single block, which at the time of filing for a permit is designated by its owner or developer as a tract to be used, developed or built upon as a unit, under single ownership or control. A zoning lot shall satisfy zoning ordinance requirements with respect to area, size, dimensions, and frontage as required in the district in which the zoning lot is located. A zoning lot, therefore, may not coincide with a lot of record as filed with the County Register of Deeds, but may include one (1) or more lots of record. *(amended 08.06.98)*

Marginal Access Road: A service roadway parallel to a feeder road; and which provides access to abutting properties and protection from through traffic. (See Illustration 2.6)

Master Plan: The comprehensive plan including graphic and written proposals indicating the general location for streets, parks, schools, public buildings and all physical development of the Township and includes any unit or part of such plan, and any amendment to such plan or parts thereof. Such plan shall be adopted by the Planning Commission and may or may not be adopted by the Township Board.

Master Right-of-Way Plan: The right-of-way and/or thoroughfare plan officially adopted by the Township Board, the Road Commission for Oakland County (RCOC), and the Inter County Highway Commission.

Mezzanine: An intermediate floor in any story occupying more than one-third (1/3) of the floor area of such story, but which extends over only part of the main floor.

Mini-Warehouse: A building that consists of several individual storage units, each with a separate door and lock and which can be leased on an individual basis.

Mobile Home: A structure designed or used for residential occupancy built upon or having a frame or chassis to which wheels may be attached by which it may be moved upon a highway, whether or not such structure actually has, at any given time, such wheels attached, or is jacked up or skirted.

Mobile Home Park: Any plot of ground upon which two or more mobile homes, occupied for permanent residential purposes, are or may be located in compliance with the Mobile Home Commission Rules and Michigan Public Act 419 of 1976, as amended.

Motel: See Hotel.

Motor Home: A motor vehicle constructed or altered to provide living quarters, including permanently installed cooking and sleeping facilities, and is used for recreation, camping, or other non-commercial use. *(amended 08.05.99)*

Natural Features: Natural features shall include soils, wetlands, floodplain, water bodies, topography, vegetative cover, and geologic formations.

Non-Conforming Building: A building or portion thereof lawfully existing at the effective date of this Ordinance, or amendments thereto, and which does not conform to the provisions of the Ordinance in the zoning district in which it is located.

Non-Conforming Use: A use which lawfully occupied a building or land at the effective date of this Ordinance, or amendments thereto, and that does not conform to the use regulations of the zoning district in which it is located. (See Illustration 2.7)

Nuisance: An act, condition, thing, structure, or person which is offensive, annoying, unpleasant, and/or obnoxious.

Nursery, Plant Material: A space, building or structure, or combination thereof, for the growth and storage of live trees, shrubs, or plants offered for retail sale on the premises including products used for gardening or landscaping. The definition of nursery within the meaning of this Ordinance does not include any space, building or structure used for the sale of fruits, vegetables or Christmas trees.

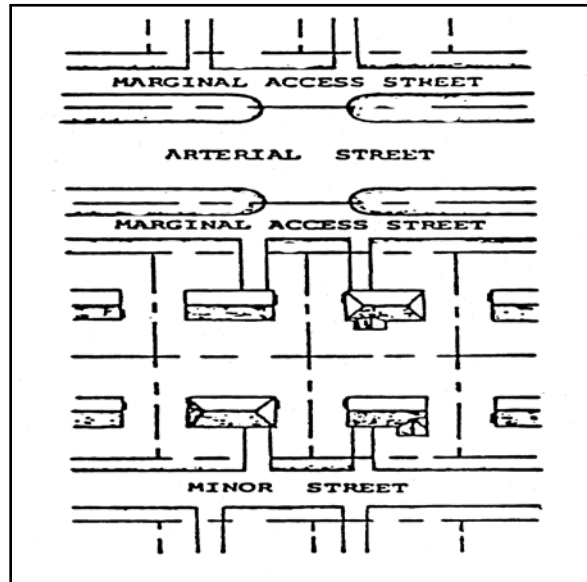

Illustration 2.6

Occupant Load: The occupant load of an establishment or use is the maximum number of persons who can avail themselves of the services or goods of such establishment at any one time with reasonable safety and comfort, as determined by the Township's adopted Building Code, Ordinance No. 130, as amended.

Open Air Business: A business operating on a seasonal or temporary basis which is wholly or partially conducted outside of a building. This may include temporary locations for Christmas trees, pumpkins, fireworks, etc., but shall exclude outdoor display and sales as defined below. *(amended 06.04.12)*

Outdoor Display and Sales: Incidental sales and display area located outside of the principal building which does not exceed ten percent (10%) of the principal building area or one thousand (1,000) square feet, whichever is less. The outdoor display and sales shall be related to the existing principal use of the property. *(amended 06.04.12)*

Outdoor Storage: The keeping, in an unroofed area, of any goods, junk, material, merchandise or vehicles in the same place for more than twenty-four (24) hours. *(added 02.01.16)*

Outlot: A parcel of land not subject to other conditions of a plat but which must be designated on a recorded plat as an outlot before it may be legally considered as such.

Parcel: *(amended 08.07.97)* A piece of land under single ownership and control that is at least sufficient in size to meet minimum zoning requirements for use, coverage, and area, and to provide such yards and other open spaces as are herein required. Such parcel shall have frontage on a permanent easement, or a dedicated roadway or on a permitted private road as may be provided by appropriate ordinance. Such parcel may consist of:

- A. A single lot of record;
- B. A portion of a lot of record;
- C. A combination of complete lots of record, or portions thereof;
- D. A piece of land described by metes and bounds; provided that in no case of division or combination shall any residual lot or parcel be created which does not meet the requirements of this Ordinance.

Parking Space: An area of definite length and width designated for parking an automobile or motor vehicles, such space being exclusive of necessary drives, aisles, entrances or exits and being fully accessible for the storage or parking of permitted vehicles.

Personal Wireless Service Antennae: Antennae used to send or receive PWS signals. *(amended 08.21.97)*

Personal Wireless Service (PWS) Facilities: As initially defined by the Telecommunication Act of 1996 to include commercial mobile services, unlicensed wireless services and common carrier wireless exchange access

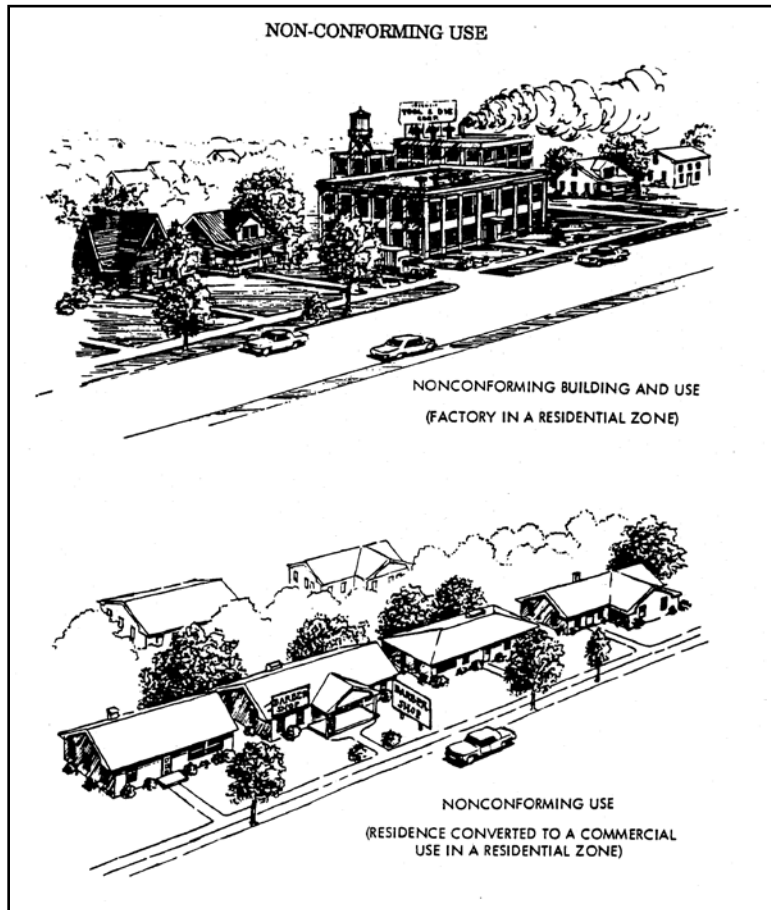

Illustration 2.7

services and intended to include telecommunications by Cellular, Personal Communication Service (PCS) or Specialized Mobile Radio (SAR) methods. *(amended 08.21.97)*

Personal Wireless Service Support Structure: A structure used to support PWS antennae. *(amended 08.21.97)*

Personal Wireless Service Tower: A freestanding structure, attached to the ground and used to support PWS antennae. *(amended 08.21.97)*

Planned Unit Development: A planned unit development (PUD) may include such concepts as cluster development, planned development, community unit plan, planned residential development, and other terminology denoting special zoning requirements and review procedures. These requirements and procedures are intended to provide design and regulatory flexibility, so as to accomplish the objectives of this Ordinance using innovative and effective planning approaches. *(amended 04.10.86)*

Planning Commission: The Planning Commission of the Charter Township of Orion.

Principal Use: The main use to which the premises are devoted and the main purpose for which the premises exist.

Private Road: See Street, Private.

Public Service Facilities: These include such uses and services as voting booths, pumping stations, fire halls, police stations, temporary quarters for welfare agencies, public health activities and similar uses including essential services.

Public Utility: Any person, firm, corporation, municipal department, or board, duly authorized to furnish and furnishing to the public under governmental regulations, electricity, gas, steam, communications, telegraph, transportation, water services, sewers or sewage treatment.

Recognizable and Substantial Benefit: A clear benefit, both to the ultimate users of the property in question and to the community, which would reasonably be expected to accrue, taking into consideration the reasonably foreseeable detriments of the proposed development and use(s). Such benefits may include: long-term protection or preservation of natural resources and natural features, historical features, or architectural features; or, elimination of reduction in the degree of nonconformity of a nonconforming use or structure.

Recreational Vehicle: These uses shall be defined as follows: *(added 11.15.10)*

- A. Boats and Boat Trailers. Includes boats, jet skis, floats, rafts, canoes, plus the normal equipment to transport them on the highway.
- B. Folding Tent Trailer. A canvas folding structure mounted on wheels and designed for travel and vacation use.
- C. Motor Home. A recreational vehicle intended for temporary human habitation, sleeping, and/or eating, mounted upon a chassis with wheels and capable of being moved from place to place under its own power. Motor homes generally contain sanitary, water, and electrical facilities.
- D. Other Recreational Equipment. Includes snowmobiles, all-terrain or special terrain vehicles, utility trailers, plus the normal equipment to transport them on the highway.
- E. Pickup Camper. A structure designed to be mounted on a pickup or truck chassis with sufficient equipment to render it suitable for use as a temporary dwelling during the process of travel, recreational, and vacation uses.
- F. Travel Trailer. A portable vehicle on a chassis which is designed to be used as a temporary dwelling during travel, recreational, and vacation uses, and which may be identified as a "travel trailer" by the manufacturer.

Refuse: Solid wastes, except human or animal wastes and includes garbage, rubbish, ashes, incinerator ash, incinerator residue, street cleaning, solid market and solid industrial waste.

Restaurant: A restaurant is any establishment whose principal business is the sale of foods, desserts, or beverages to the customer in a ready-to-consume state, and whose method of operation is characteristic of a drive-in, drive through, fast food, or full service restaurant, or a combination thereof, as defined below. Restaurant use may also include outdoor patio with tables and chairs. *(added 02.16.10)*

Restaurant, Drive-In: A drive-in restaurant is any establishment whose principal business is the sale of foods, desserts, or beverages to the customer in a ready-to-consume state, and whose method of operation involves delivery of the prepared food, so as to allow their consumption in a motor vehicle or elsewhere on the premises, but outside of an enclosed structure.

Restaurant, Drive-Through: A drive-through restaurant is any establishment whose principal business is the sale of food, desserts, or beverages to the consumer in a ready-to-consume state, and whose method of operation involves the delivery of the prepared food to the customer in a motor vehicle, typically through a drive-through window, for consumption off the premises.

Restaurant, Fast-Food: A fast-food restaurant is any establishment whose principal business is the sale of foods, desserts, or beverages to the customers in a ready-to-consume state, and whose method of operation involves delivery of the prepared food to the customer at a counter or cafeteria line for consumption at the counter where it is served, or at tables, booths, or stands inside the structure or out, but not in a motor vehicle on the site.

Restaurant, Full-Service: A full-service restaurant is any establishment whose principal business is the sale of foods, desserts, or beverages to the customers in a ready-to-consume state, and whose method of operation involves the delivery of the prepared food by waiters or waitresses to customers seated at tables within a completely enclosed building.

Restaurant, Outdoor Café: An outdoor area adjoining a restaurant consisting of tables, chairs, plantings and related decorations, where one (1) or more of the following is provided: live music, amplified music, dancing, staged entertainment or service of alcoholic beverages. *(added 02.16.10)*

Restaurant, Outdoor Patio: An outdoor area adjoining a restaurant consisting of tables and chairs, and which is limited to a size which is not greater than twenty-five (25%) percent of the gross floor area of the restaurant that does not include live music, amplified music, dancing, stage entertainment or service of alcoholic beverages. *(added 02.16.10)*

Right-of-Way: Land used or to be used, either public or private, to facilitate pedestrian and/or vehicular movement.

Road: A public or private right-of-way which affords traffic circulation and principal means of access to abutting property, including avenue, place, way, drive, lane, boulevard, highway, street, and any other thoroughfare, except an alley or driveway to a building. A road also includes the land between the road lines, whether improved or unimproved. *(amended 04.21.03)*

Major Thoroughfare. An arterial road of great continuity which is intended to serve as a large volume traffic-way for both the immediate Municipality area and region beyond, and which may be designated in the Township's Major Thoroughfare Plan as a major thoroughfare, parkway, expressway, or equivalent term to identify those roads comprising the basic structure of the road plan. Major thoroughfares shall also have an existing or proposed right-of-way of one hundred twenty (120) feet or more.

Collector Road (Arterial). A road used primarily to carry traffic from a minor road to a major thoroughfare. Collector roads (arterials) shall be the roads so designated in the Master Plan of the Township as having an existing or proposed right-of-way of at least eighty-six (86) feet but not more than one hundred twenty (120) feet.

Local Road. A road of limited continuity used primarily for access to abutting residential properties.

Marginal Access Road. A minor road paralleling and adjacent to a major thoroughfare which provides access to abutting properties and protection from through traffic.

Boulevard. A road developed to 2 two-lane, one-way pavements, separated by a median.

Turn-Around. A short boulevard permanently terminated by a vehicular turn-around.

Cul-de-Sac. A minor road of short length, having one (1) end open to traffic and being permanently terminated at the other end by a vehicular turn-around.

Loop Road. A minor road of short length with two (2) openings to traffic, beginning from the same road, and projecting parallel to each other and connecting at their termination by a loop.

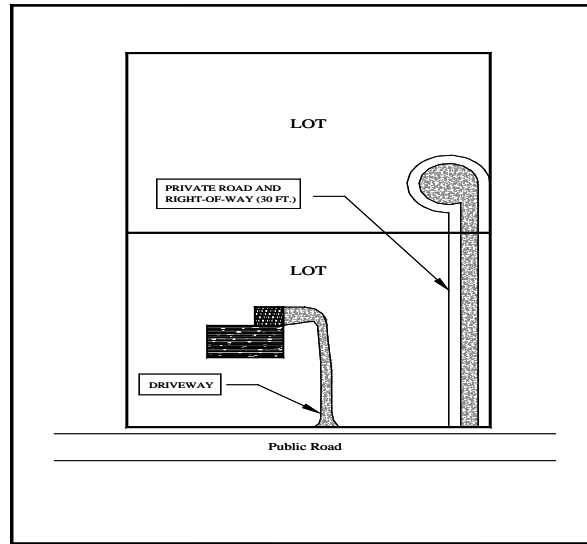

Illustration 2.10

Road, Private: A road constructed within a dedicated right-of-way, in accordance with this Ordinance, which provides vehicular access to one (1) or more parcels, where said right-of-way and road have not been dedicated to the Road Commission for Oakland County, or other public jurisdiction. (See Illustration 2.10) *(amended 04.21.03)*

Road, Public: A road accepted, by dedication or otherwise, by the Road Commission for Oakland County or the Michigan Department of Transportation. *(amended 04.21.03)*

Roadside Stands: A temporary or permanent building operated for the purpose of seasonally selling only produce raised or produced on the same premises by the proprietor of the stand or his family; its use shall not make into a commercial district land which would otherwise be an agricultural or residential district, nor shall its use be deemed a commercial activity.

Rubbish: The miscellaneous waste materials resulting from housekeeping, mercantile enterprises, trades, manufacturing and office, including other waste matter such as slag, stone, broken concrete, fly ash, ashes, tin cans, glass, scrap metal, rubber, paper, rags, or any similar or related combinations thereof.

Setback: A setback is the distance required between a front, side or rear property line and any part of a structure on the lot in order to conform to the required yard setback provision of this Ordinance. For the purposes of this Ordinance, the minimum building line shall be the same as the front setback line. *(amended 04.10.97)*

Sign: The use of a device to display any word, numeral, figure, devise, letter, symbol, insignia, illustration, design, trademark, or combination of these by which information is made known to the general public and is visible from off the site or lot, and as further defined and described in the Orion Township Sign Ordinance, Ordinance No. 153. *(amended 02.21.06)*

Sign, Accessory: A sign which is accessory to the principal use of the premises, by advertising only business transacted or goods sold or produced on the premises on which the sign is located.

Sign Area: The height multiplied by the width of the sign, including all component projections in that measurement. The sign area shall not include the supports or uprights on which the sign is placed.

Sign, Non-Accessory: A sign which is not accessory to the principal use of the premises.

Sign, Off-Premise: Any sign, including signs commonly referred to as "billboards", that contain written or pictorial information that is not directly related to the principal use of the lot on which the sign is located.

Sign, Residential Entranceway: A permanent structure, including but not limited to walls, columns and gates, marking entrances to single-family subdivisions of multiple housing projects and identifying the subdivision or project by name, symbol or otherwise.

Sign, Wall: A sign mounted on the outside wall of a building with the exposed face of the sign in a plane approximately parallel to the plane of the wall.

Soil Removal: The removal from the premises of any kind of soil or earth matter which includes topsoil, sand, gravel, clay or similar materials or any combination thereof, except for soil removal related to common household gardening and general farm care.

Special Land Use: Special land uses are uses, either public or private, which possess unique characteristics and therefore cannot be properly classified as a permitted use in a particular district or districts. After due consideration of the impact of each such use upon neighboring land and of the public need for the particular use at the particular location, such special land uses may or may not be permitted by the Planning Commission, subject to the terms of this Ordinance.

Stable, Private: A stable is an enclosed structure intended for the keeping of horses, cows, and other livestock for the noncommercial use of the residents of the principal use, provided, however, that two and one-half (2-1/2) acres of land is required for the first horse or other animal and one (1) acre apiece for each additional horse or animal. A stable shall not include the keeping of horses or other animals for others, or for commercial boarding.

Stable, Public: A stable other than a private stable, with a capacity for more than two (2) horses, and carried on within an unplatted tract of land of not less than forty (40) acres.

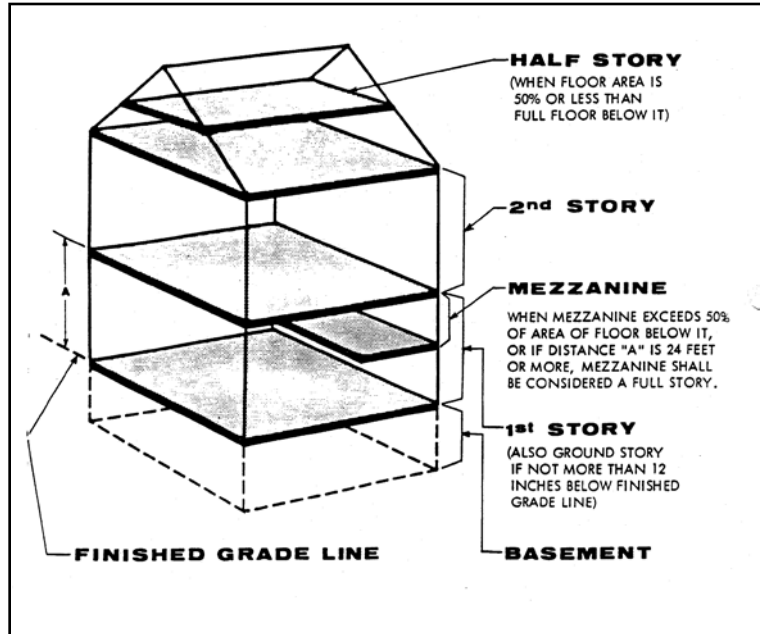

Illustration 2.8

State Licensed Residential Facility: A structure constructed for residential purposes that is licensed by the State under the Adult Foster Care Facility Act, and provides residential services for six (6) or fewer persons under 24-hour supervision or care. (amended 08.06.07)

Story: That portion of a building, other than a basement or mezzanine, included between the surface of any floor and the floor next above it, or, if there be no floor above it, then the ceiling above. A "mezzanine" shall be deemed a full story when it covers more than fifty percent (50%) of the area of the story underneath said mezzanine, or, if the vertical distance from the floor next below it to the floor next above it is twenty-four (24) feet or more. (See Illustration 2.8)

Story, Ground: The lowest story which cannot be considered a basement in a building.

Story, Half: The part of a building between a pitched roof and the uppermost full story, said part having a finished floor area which does not exceed two-thirds (2/3) the floor area of said full story.

Street: See Road.

Street, Private: See Road, Private.

Street, Public: See Road, Public.

Structure: Anything constructed or erected with a fixed location on or in the ground, or attached to something having a fixed location on or in the ground. Structures include principal and accessory buildings, farm buildings, mobile homes, swimming pools, and signs.

Structure Area: The sum of the gross horizontal areas of all floors, measured from the outside walls of the principal building and all accessory buildings, including basements, elevator shafts, and stairwells at each story, floor space used for mechanical equipment, penthouses, half stories, mezzanines, and interior balconies. (See Illustration 2.4)

Structural Alteration: Any change in the supporting members of a building or structure, such as bearing walls or partitions, columns, beams or girders or any change in the width or number of exits, or any substantial change in the roof.

Subdivision Plat: The division of land in accordance with the Plat Act, Act 288 of the Public Acts of 1967, as amended.

Swimming Pool: Any permanent, nonportable structure or container located either above or below grade designed to hold water to a depth of greater than twenty-four (24) inches, intended for swimming or bathing. A swimming pool shall be considered an accessory structure for purposes of computing lot coverage.

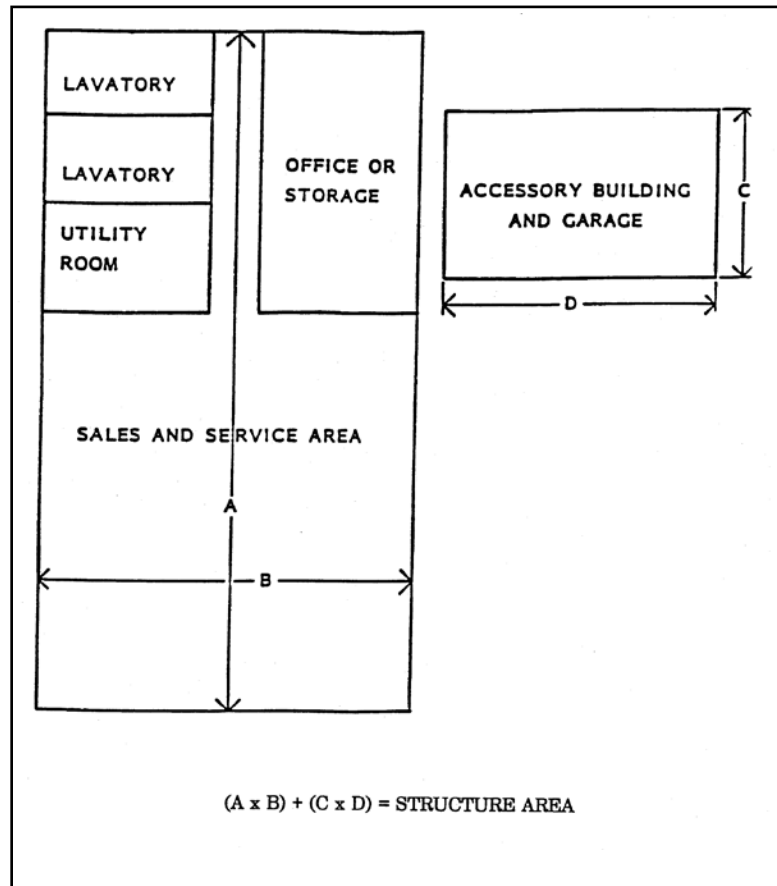

Illustration 2.4

Swimming Pool Club, Private (Non-Profit): A private club incorporated as a

non-profit club or organization, maintaining and operating a swimming pool, with specified limitations upon the number of members, or limited to residents of a block, subdivision, neighborhood, community, or other specified area of residence, for the exclusive use of members and their guests.

Swimming Pool, Private: A swimming pool and the apparatus and equipment pertaining to the swimming pool maintained by an individual for the sole use of his household and guests without charge for admission and not for the purpose of profit or in connection with any business operated for profit, located on a lot as an accessory use to a residence.

Tattoo and Body Art Piercing: Means any facility that provides, as a principal function, the service of providing a tattoo, an indelible mark, figure or appendage, fixed upon the body by placement of a pigment, dye or other insertion under the skin, or by production of scars. (added 02.19.08)

Temporary Building or Use: A structure or use permitted by the Board of Appeals to exist during periods of construction of the main use, or for special events.

Township: The Charter Township of Orion, Oakland County, Michigan.

Township Board: The Township Board of the Charter Township of Orion, Oakland County, Michigan.

Travel Homes (also Travel Trailers): Any structure intended for or capable of human habitation, sleeping or eating, mounted upon wheels and capable of being moved from place to place, either by its own power or power supplied by some other vehicle attached thereto. This definition shall include all such vehicles eight (8) feet or under in width and thirty-two (32) feet or under in length. Such definition shall include travel trailers, motor homes, campers, etc.

Underlying Zoning: The zoning classification and regulations applicable to the property immediately preceding the approval of an application to designate the property Planned Unit Development.

Usable Floor Area: Eighty percent (80%) of the gross floor area.

Use, Accessory: An accessory use is a use which is clearly incidental to, customarily found in connection with, and is located on the same zoning lot as, the principal use to which it is related.

Use, Permitted: A permitted use is a use which may be lawfully established in a particular district or districts provided it conforms with all requirements, regulations, and standards of such district.

Use, Principal: The principal use is the main use of land and buildings and the main purpose for which the land and buildings exist.

Use, Special Land: Special land uses are uses, either public or private, which possess unique characteristics and therefore cannot be properly classified as a permitted use in a particular district or districts. (See "Special Land Use")

Wireless Communication Facilities or Facility: Shall mean all structures and accessory facilities relating to the use of the radio frequency spectrum for the purpose of transmitting or receiving radio signals or other wireless communications services, and include wireless communications equipment, wireless communications support structures, and wireless communications equipment compounds, as defined herein. This may include, but shall not be limited to, radio towers, television towers, telephone devices and exchanges, microwave relay towers, telephone transmission equipment buildings and commercial mobile radio service facilities. Not included within this definition are citizen band radio facilities, short wave facilities, ham amateur radio facilities, private/stand-alone satellite dishes, essential services structures and facilities, and governmental facilities which may be subject to state or federal law or regulations which preempt municipal regulatory authority. For purposes of this Chapter, the following additional terms are defined: *(added 09.02.14)*

- A. Attached Wireless Communications Facilities shall mean wireless communication equipment attached to an existing wireless communications support structure or in an existing wireless communications equipment compound.
- B. Substantial change in physical dimensions means one or more modifications of the height, width, length, or area of a wireless communications facility at a location, the cumulative effect of which is to materially alter or change the appearance of the wireless communications facility.
- C. Wireless communications equipment means the equipment and components, including antennas, transmitters, receivers, base stations, equipment shelters or cabinets, emergency generators, and power supply, coaxial and fiber optic cables used in the provision of wireless communications services, but excluding wireless communication support structures.
- D. Wireless communications equipment compound means a delineated area surrounding or adjacent to the base of a wireless communications support structure within which any wireless communications equipment related to that support structure is located.
- E. Wireless Communication Support Structures or Support Structures shall mean structures designed to support or capable of supporting wireless communication equipment. Support structures within this definition include, but shall not be limited to, monopoles, lattice towers, utility poles, wood poles and guyed towers, buildings, or other structures with such design capability.

- F. Collocation shall mean the location by two (2) or more cellular communication providers of cellular communication facilities on a common wireless communication support structure.

Variance: A modification of the literal provisions of the Zoning Ordinance granted when strict enforcement of the Zoning Ordinance would cause undue hardship owing to circumstances unique to the individual property on which the variance is granted. The crucial points of variance are (a) undue hardship, (b) unique circumstances, and (c) applying to property. A variance is not justified unless all three elements are present in the case. As used in this Ordinance, a variance is authorized only for height, area, and size of structure or size of yards and open spaces. Establishment or expansion of a use otherwise prohibited shall not be allowed by variance, nor shall a variance be granted because of the presence of non-conformities in the zoning district or uses in an adjoining zoning district.

Veterinary Clinic: A place for the care, diagnosis and treatment of sick or injured animals, and those in need of medical or minor surgical attention. A veterinary clinic may include customary pens or cages which are permitted only within the walls of the clinic structure.

Wetlands: Land characterized by the presence of water at a frequency and duration sufficient to support, and that under normal circumstances, does support wetland vegetation or aquatic life and is commonly referred to as a bog, swamp, or marsh, and which is any of the following: *(added 09.17.07)*

- A. Contiguous to an inland lake or pond, or a river or stream.
- B. Not contiguous to an inland lake or pond, or river or stream; and more than two (2) acres in size.
- C. Not contiguous to an inland lake or pond, or a river or stream; and five (5) acres or less in size, if the Department of Natural Resources determines that protection of the area is essential to the preservation of the natural resources of the State from pollution, impairment, or destruction, and the Department has so notified the owner.
- D. Two (2) acres or less in size if the Township determines that the protection of the area is essential to the preservation of the natural resources of the Township from pollution, impairment, or destruction, and provided that the Township has made a determination that the wetland meets at least one of the criteria set forth in Section 5.00 (B) (1-10) of Ordinance No. 107.

Wind Energy Conversion System (WECS): Any device such as a wind charger, windmill, or wind turbine that converts wind energy to a form of electrical energy greater than one (1) kilowatt. *(added 02.01.10)*

- A. Private WECS: Any WECS that is accessory to a principal use located on the same lot, and is designed and built to serve the needs of the principal use which may provide some electricity back into the power grid when needs of principal use are exceeded.
- B. Commercial WECS: Any WECS that is designed and built to provide electricity to the electric utility's power grid as an ongoing commercial enterprise and/or for profit.
- C. Temporary WECS: Any WECS not permanently affixed to a structure or the ground and will serve a need for no more than 365 days.

Manual and Automatic Controls: A device that gives protection to power grids and limit rotation of WECS blades to below the designed limits of the conversion system.

Authorized Factory Representative: An individual with technical training of a WECS who has received factory installation instructions and is certified in writing by the manufacturer of the WECS.

Professional Engineer: Any licensed engineer registered in the State of Michigan.

Utility Scale Wind Farm: All wind farms that produce greater than fifty (50) kilowatts of energy.

Facility Abandonment: Out of production for a period of time more than 365 days.

Shadow Flicker: A term used to describe what happens when rotating wind turbine blades pass between the viewer and the sun, causing an intermittent shadow.

Yard: An open space on the same lot with a building, unoccupied and unobstructed from the ground upward, except as otherwise provided in this Ordinance. The measurement of a yard is the minimum horizontal distance between the lot line and the building or structure. (See Illustration 2.3)

Yard, Front: An open space extending the full width of the lot. The depth of the front yard shall be the minimum horizontal distance between the front lot line and the nearest line of the building on the lot.

Yard, Rear: An open space extending the full width of the lot, the depth of which shall be the minimum horizontal distance between the rear lot line or zoning district line, whichever is closer to the building and the nearest point of the main building.

Yard, Side: An open space between a main building and the side lot line, extending from the front yard to the rear yard, the width of which shall be the horizontal distance from the nearest point of the side lot line or zoning district line, whichever is closer to the building and the nearest point of the main building.

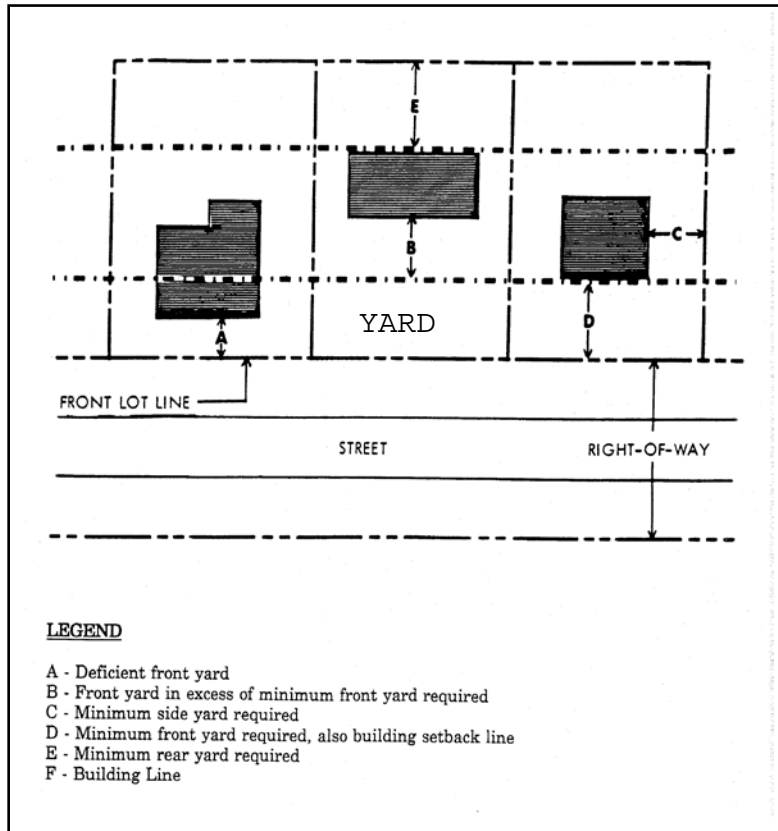

Illustration 2.3

This page intentionally blank